

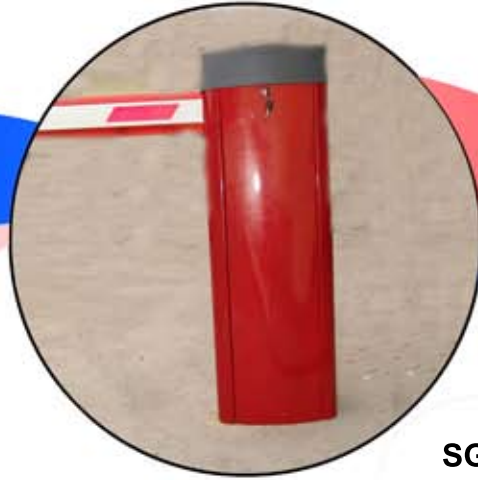

Singapore

SmartGate Car Park Barrier



SG3-HS



High Quality

Extremely Durable

Fast Speed

Powerful

Features:

* *Opening / Closing Speed - 1 Second*

- * Anti-Crushing Safety in opening and closing of barrier
- * Limit Switch for stopping opening and closing of barrier, mechanically and electronically adjustable
- * Built-In control unit can be unhooked to facilitate wiring and servicing
- * Comes with manual over-riding
- * Opening and closing of barrier is operated by:
 - 1) Remote Control
 - 2) Vehicle Loop Detector

Technical Specifications

Specifications	SG3-HS		
Min Operation Time (s)	1	Work Cycle (%)	80
Power (Vac 50/60Hz)	230	Weight (kg)	51
Power Consumption (W)	200	Dimension (mm)	268 x 320 x 1008
Current Consumption (A)	≤1	Length of Barrier (M)	3
Motor Consumption (A)	≤1	Casing Material	Steel
Reduction Ratio	1/37	Finishing of Casing	Powder Coated
Operation Temperature	-20° ~ + 70°C	Accessories	-Mobile 'Y' Support -Fixed 'Y' Support -Photo-cell

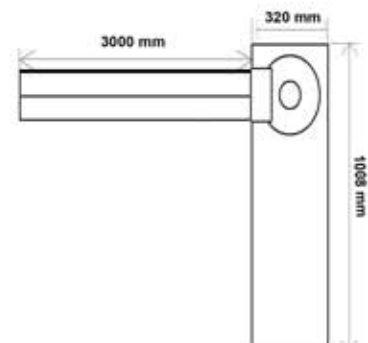

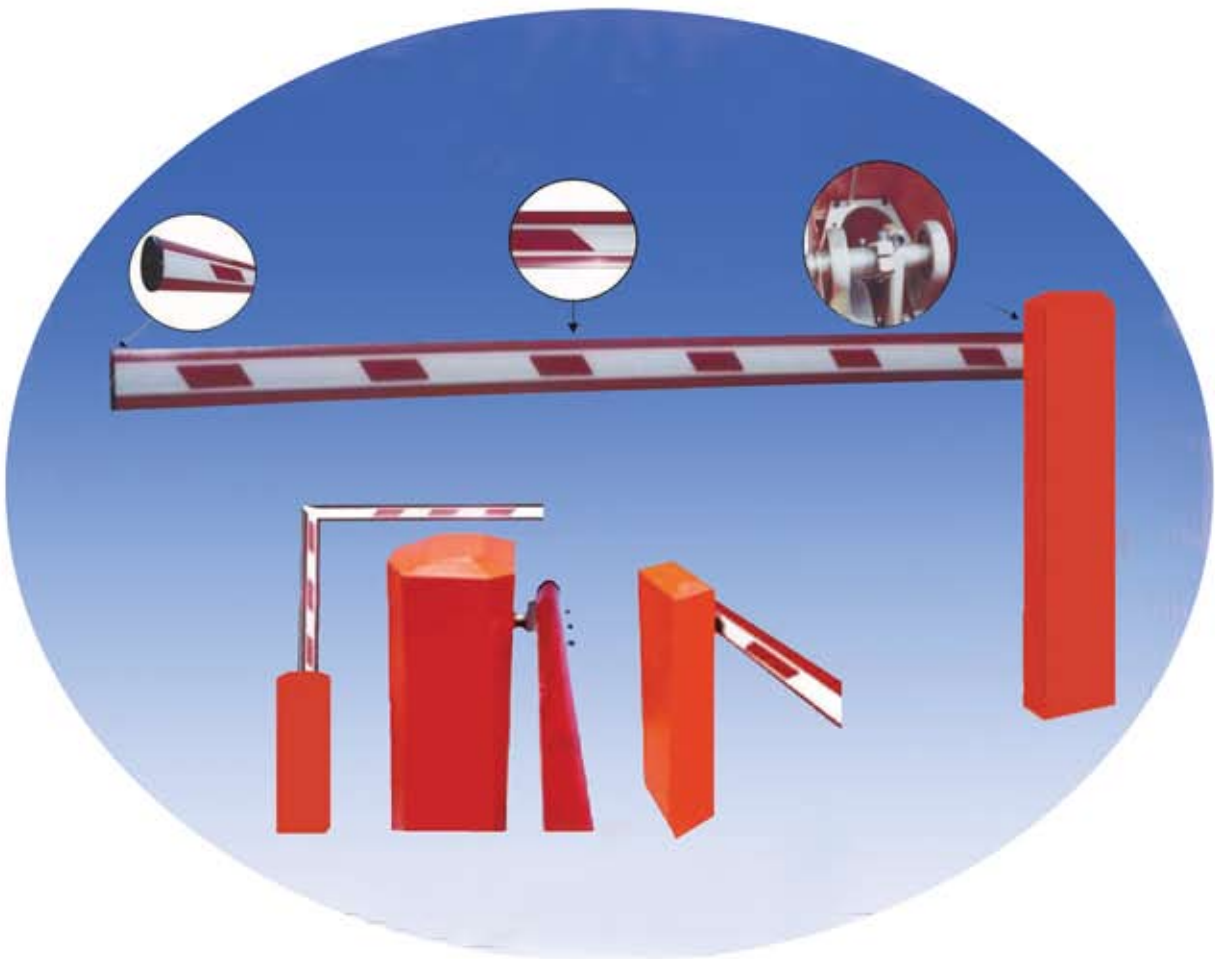

Model: SG3 / SG4 / SG6

Features:

- * Anti-Crushing Safety in opening and closing of barrier
- * Limit Switch for stopping opening and closing of barrier, mechanically and electronically adjustable
- * Built-In control unit can be unhooked to facilitate wiring and servicing
- * Easy to balance linear adjustment of spring
- * Comes with manual over-riding
- * Opening and closing of barrier is operated by:
 - 1) Remote Control
 - 2) Vehicle Loop Detector

Technical Specifications

Specifications	SG3 / SG4 / SG6
Min Operation Time (s)	4
Power (Vac 50/60Hz)	230
Power Consumption (W)	200
Current Consumption (A)	≤ 1
Motor Consumption (A)	≤ 1
Reduction Ratio	1/37
Operation Temperature	-20 ⁰ ~ + 70 ⁰ C
Work Cycle (%)	80
Weight (kg)	45
Dimension (mm)	200 x 320 x 1008
Length of Barrier (M)	1 - 8
Casing Material	Steel
Finishing of Casing	Powder Coated

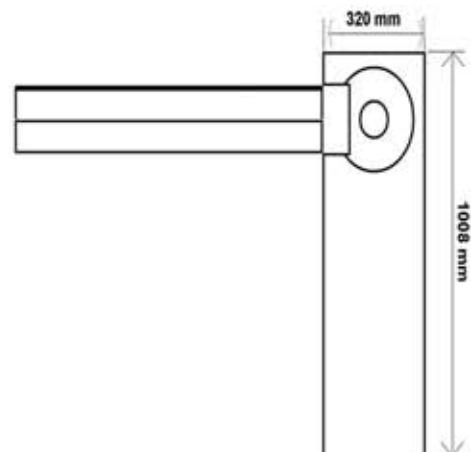

Dealer / Distributor: